



Best Practices

Beispiele aus 3DX Alliance

01. Juni 2023



Agenda

- About the 3DX Alliance
 - Who we are
 - Why 3DX Alliance
 - What Value can we bring to you
- About the customers of the 3DX Alliance
- Websites (good to know)
- Next Events

Who is the 3DX Alliance?



RALF SEIDLER
SCHWINDT | DE



JOHANN SCHOLTYSIK
IBS | PL



JANOS BARKO
HELBLING | CH



ROMAN LISIČAN
TECHNODAT | CZ, SK



GÜNTHER MÜLLER
EBM | AT



ISTVÁN NADJ
CADTERV | HU

To facilitate
digital transformation
throughout our
region and beyond.

SCHWINDT

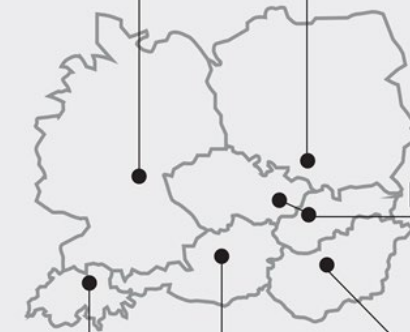

TECHNODAT

E | B | M

Cadterv

helbling

200+ employees

300+ certifications

1500+ customers

Scalable innovation

Local strength

Global know-how

Why 3DX Alliance?



3DEXPERIENCE

The 3DEXPERIENCE platform is a collaborative environment that empowers businesses to innovate in entirely new ways.



CATIA

CATIA delivers the unique ability not only to model any product, but to do so in the context of virtual twin experience.



SaaS

Cross-application services on a single platform bring together all aspects of your business to increase collaboration.



NETWORK

Join the world of 3DX ALLIANCE, the most professional and largest customer community in Europe!

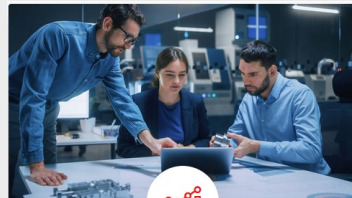

IMPLEMENTATION

We support the digitization intention with our professional experts by focusing on simplicity, efficiency.



CONSULTING

Based on best practices of successfully projects in 7 countries we lowering the risks of business transformation.

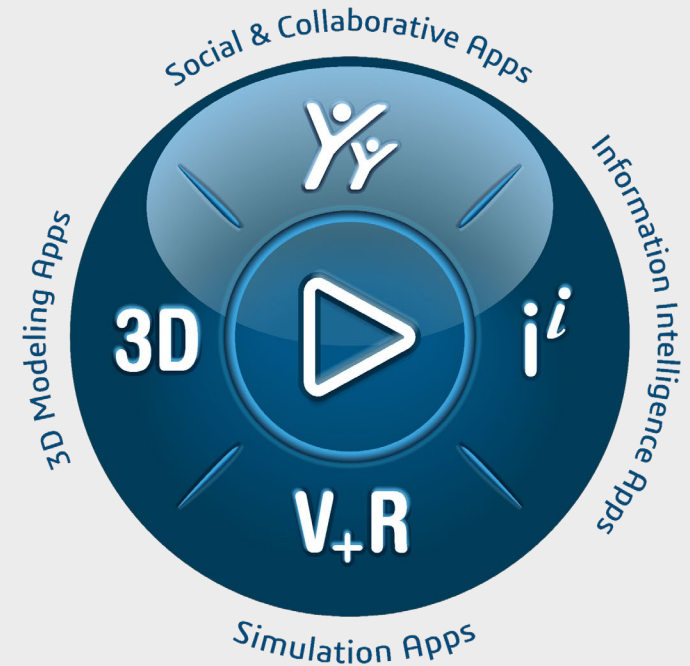

Our mission



- We support our customers in their **sustainable** expansion through our **shared resources, experience** and **expertise** in continuous collaboration.



- We leverage our resources to **facilitate the growth of our customers** in digital product development, communication and platformization.



- We bring global expertise to local needs, based on our **understanding of the local language, culture** and industrial demands.

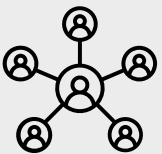

- **We simplify the implementation** and usage of digital solutions for our customers.

3DX Alliance Kunden

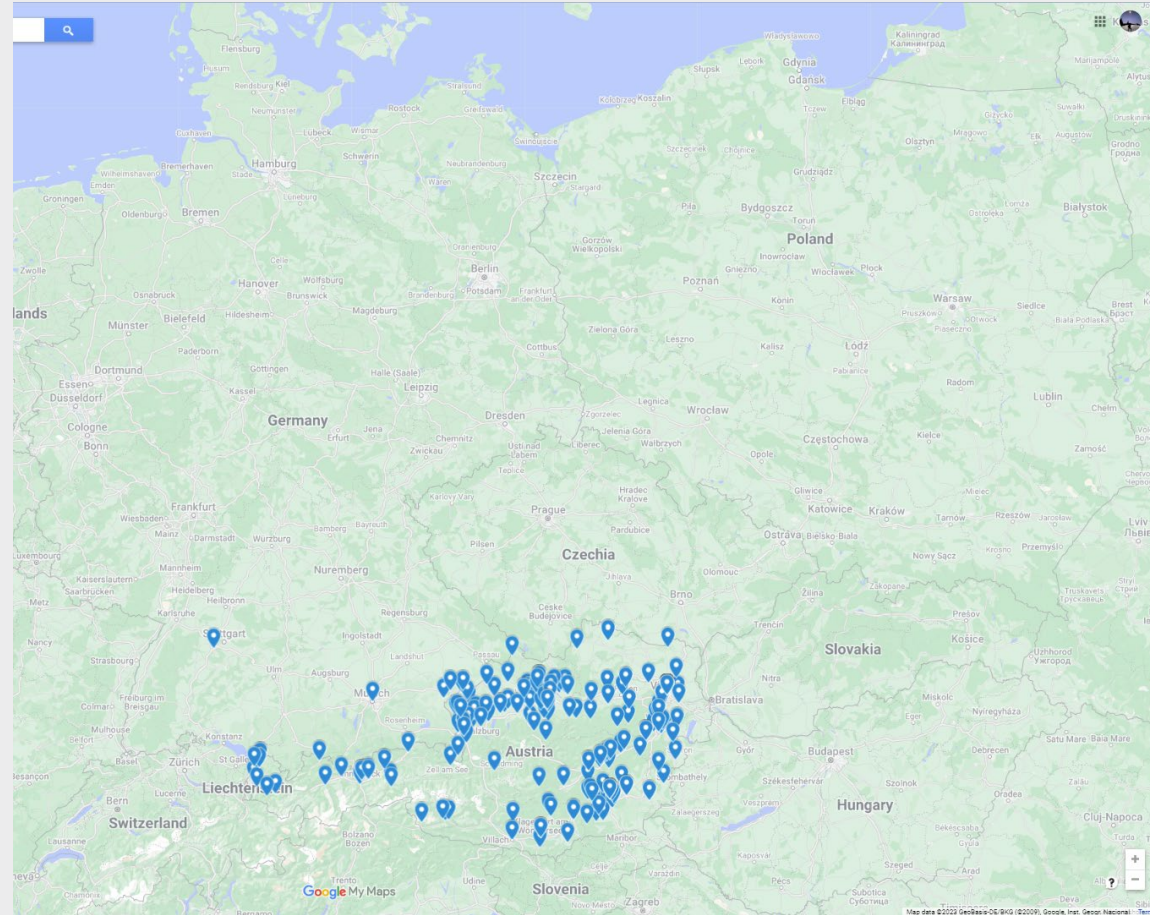

3DX Alliance Kunden

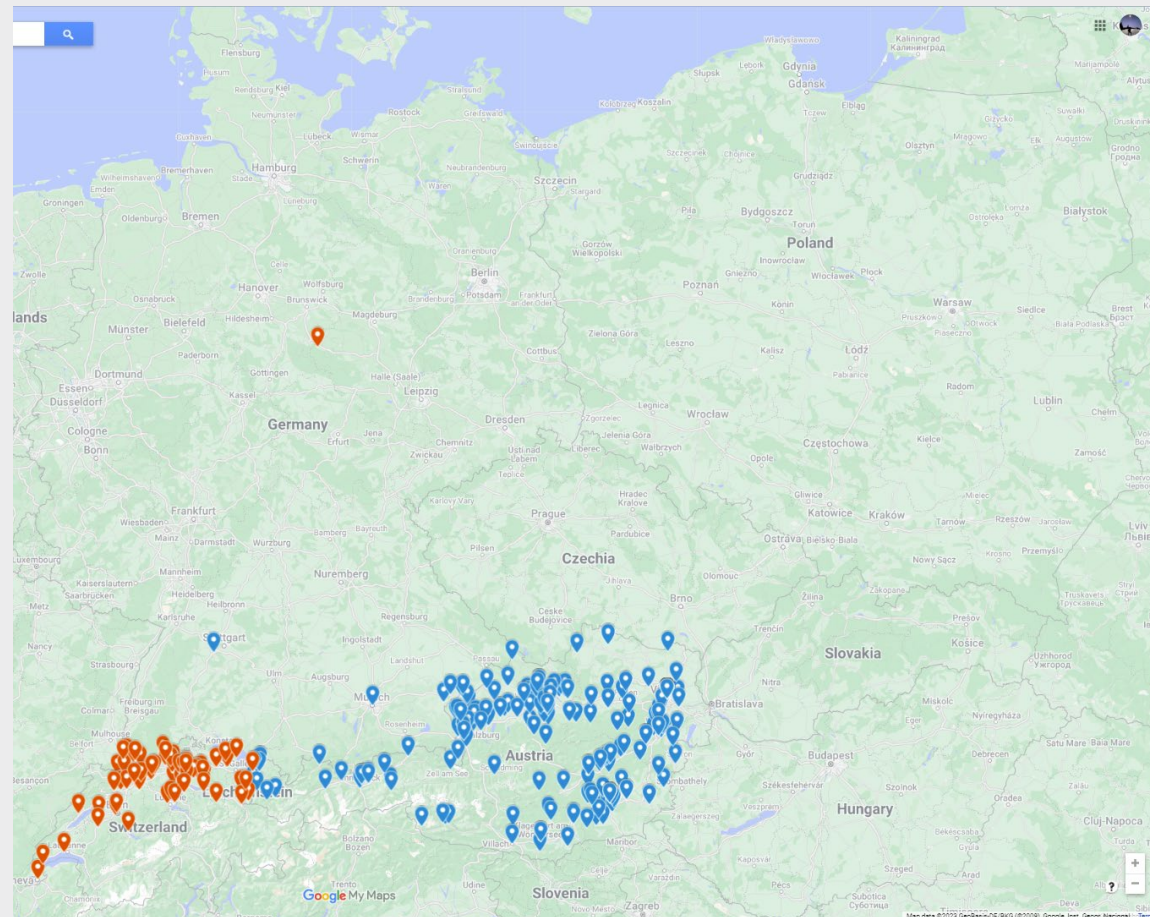

3DX Alliance Kunden

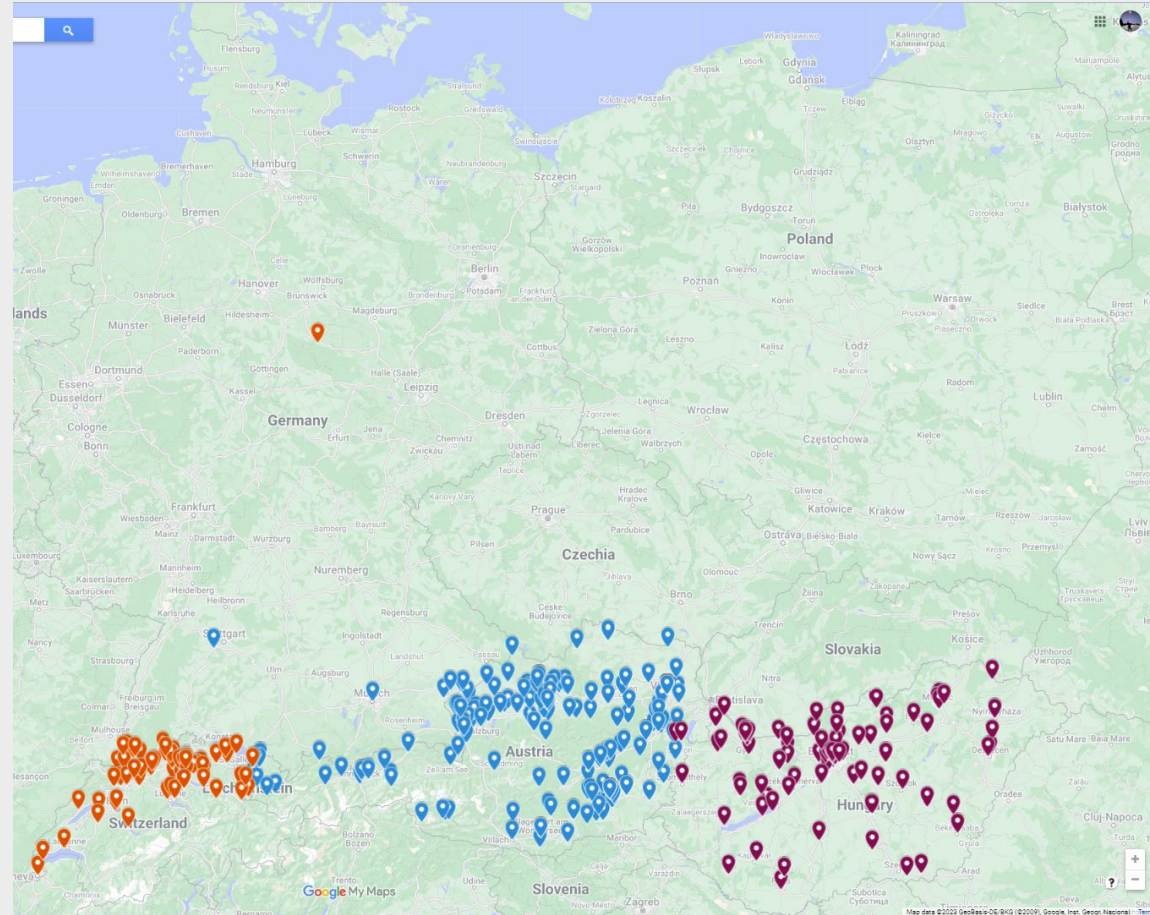

3DX Alliance Kunden

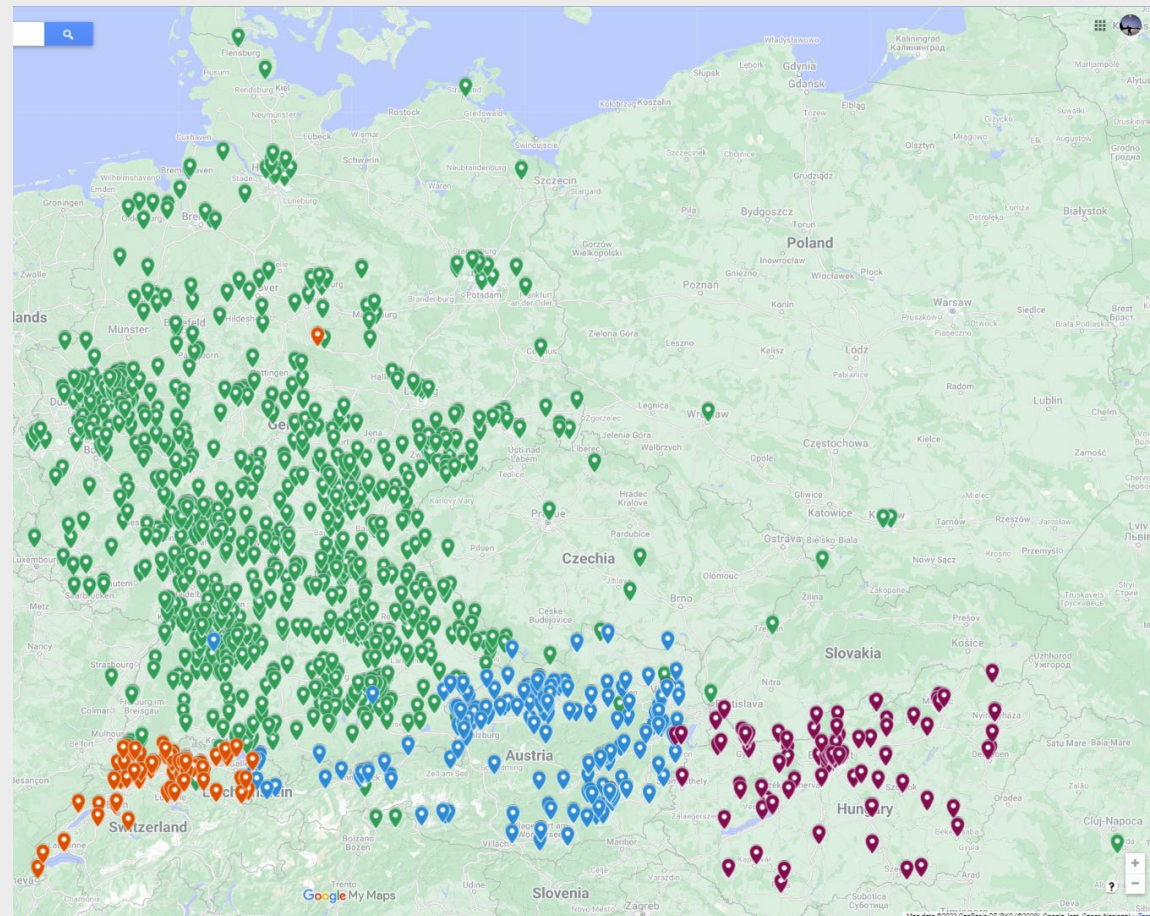

3DX Alliance Kunden

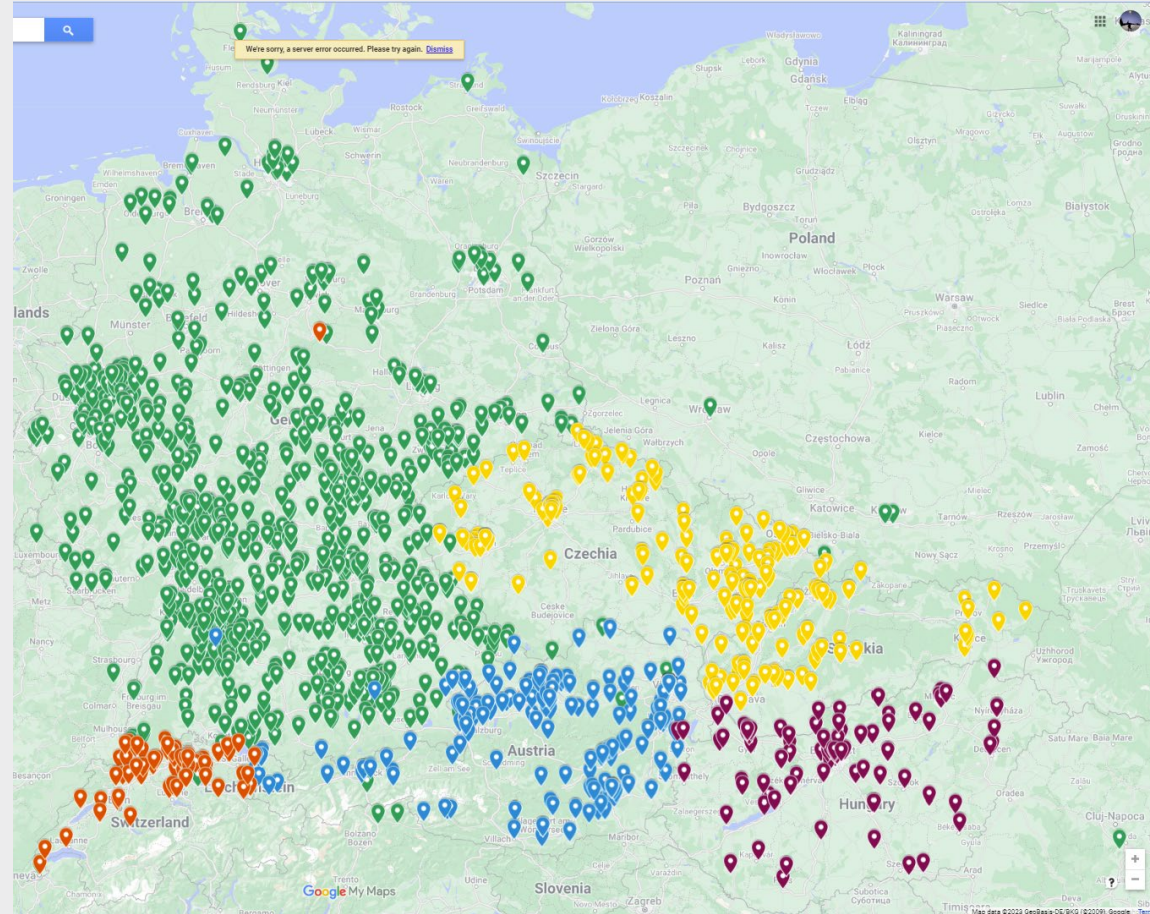

3DX Alliance Kunden

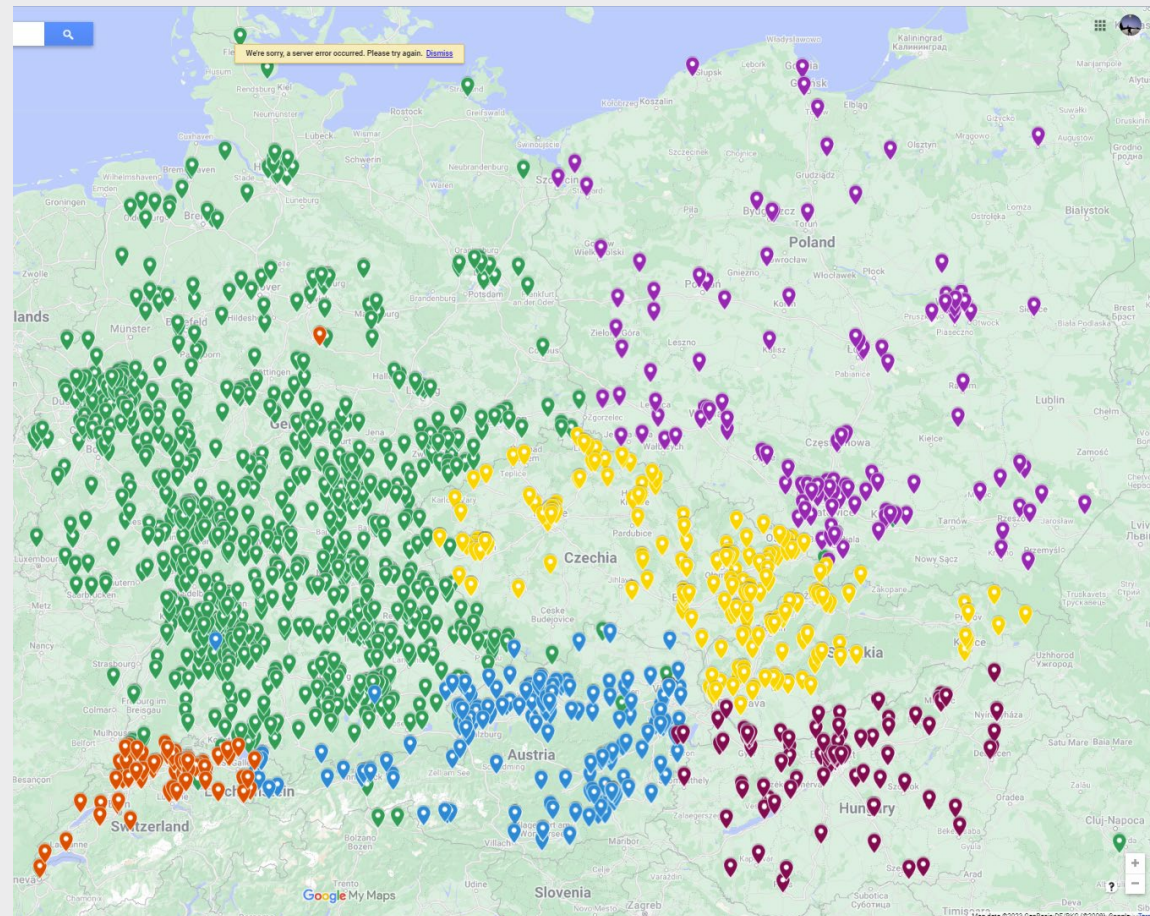



We chose the 3DEXPERIENCE platform on cloud to realize our visions of benefiting from an enterprise solution that we can expand when needed.



systematize the activities of ongoing projects, manage project time and costs, and meet its goals. respond to customer needs in the shortest possible time.



“Thanks to the 3DEXPERIENCE platform, we are now in a strong position as we have consolidated all of our activities in one single environment. “





Schweiz, Tschechien und Rumänien
Produktentwicklung mit CATIA und **3DEXPERIENCE** Plattform - On Cloud.



Designteam mit 2 Hochschulen und Helbling PLM Solutions grosser Erfolg, neuen Prozessverständnisses.



„The **3DEXPERIENCE** gives us the ability to map the requirements from the start of development to series“

«VPE/PLM» Virtuelle Produktentwicklung in einem stark wachsenden Konzern

Jürg Huber
11.05.2023

Periode 2003 – 202x (CAD to PLM)

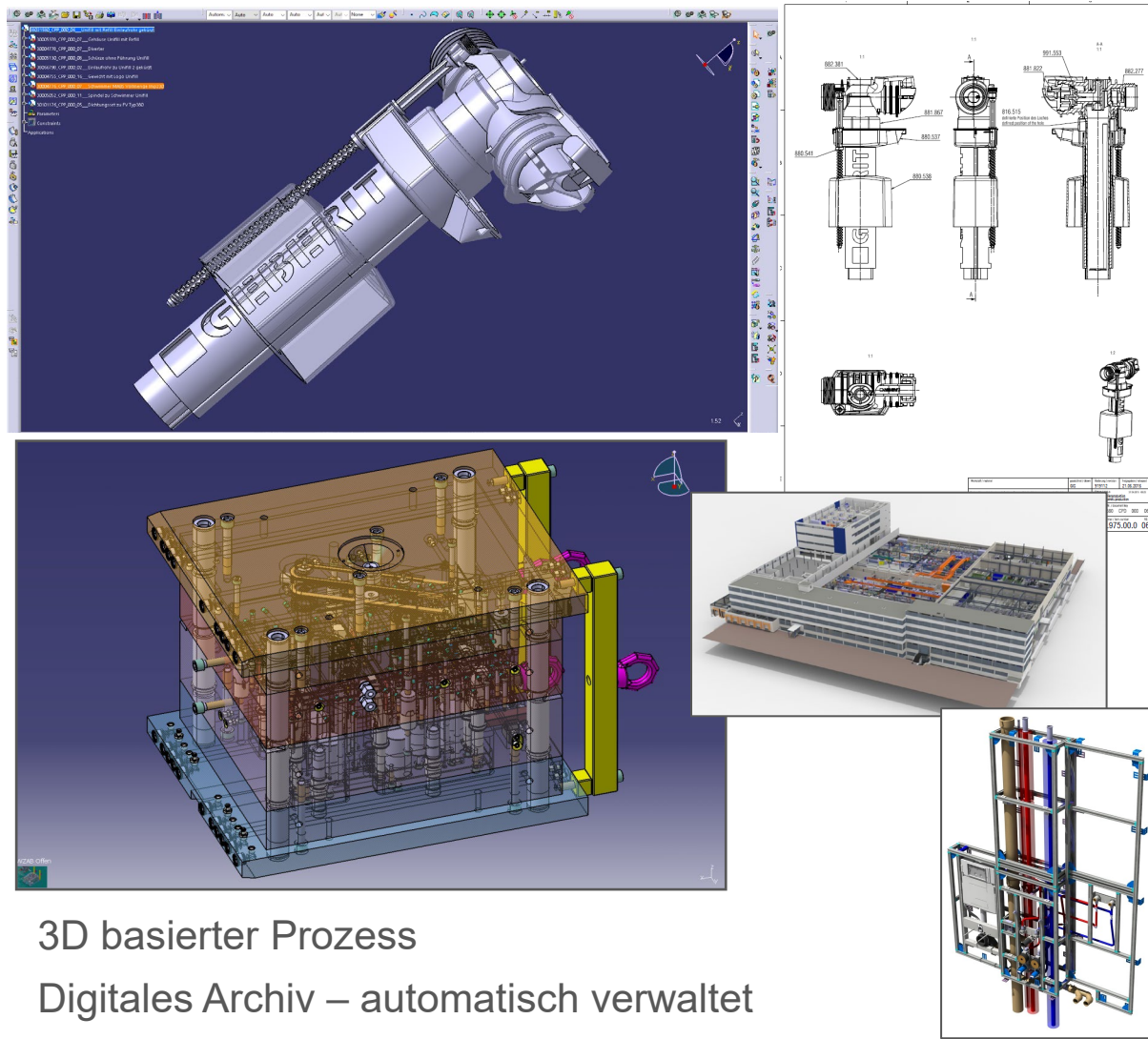

3D basierter Prozess
Digitales Archiv – automatisch verwaltet

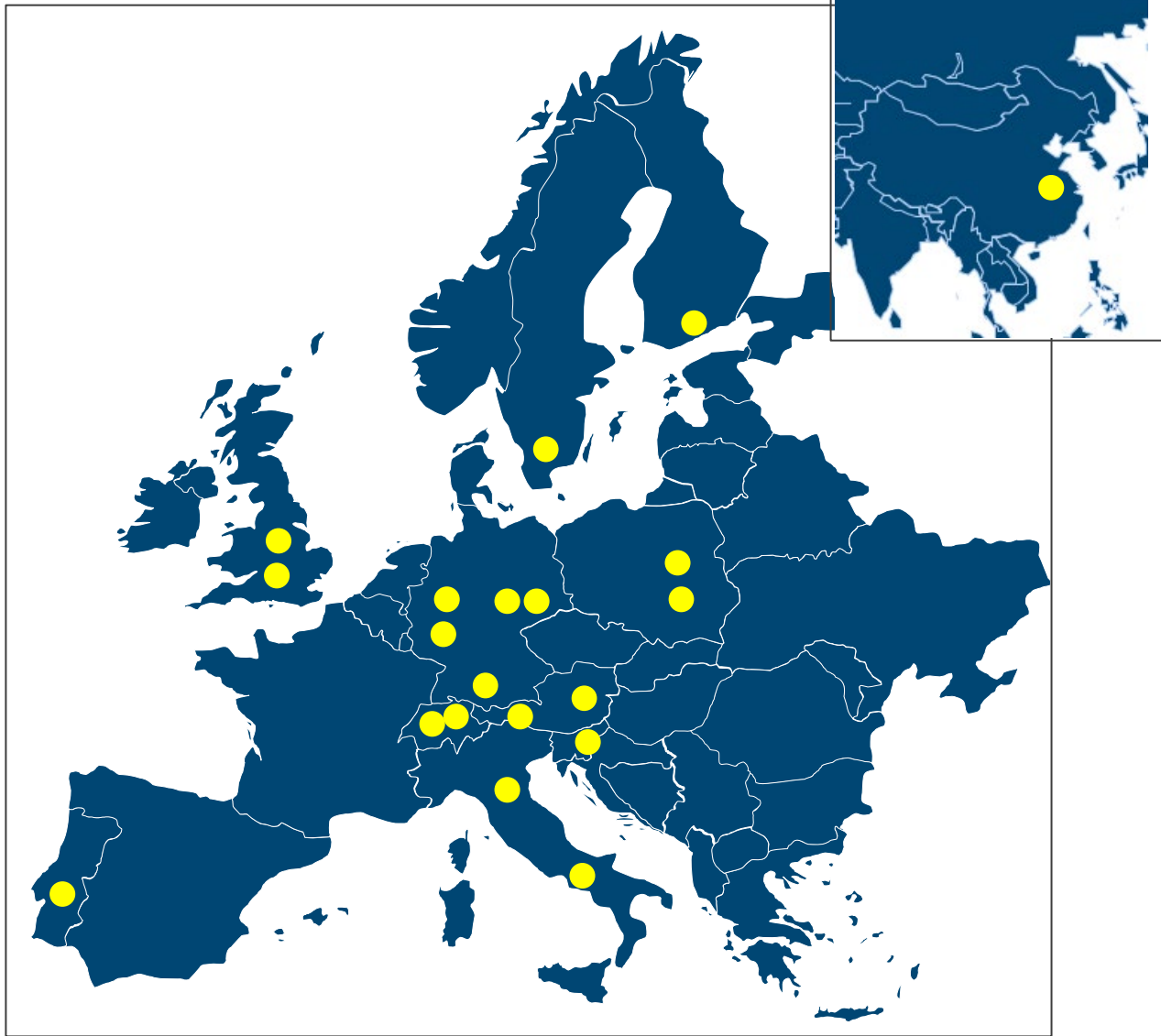

SLIDE 16

DATE 08.07.2021

■ GEBERIT

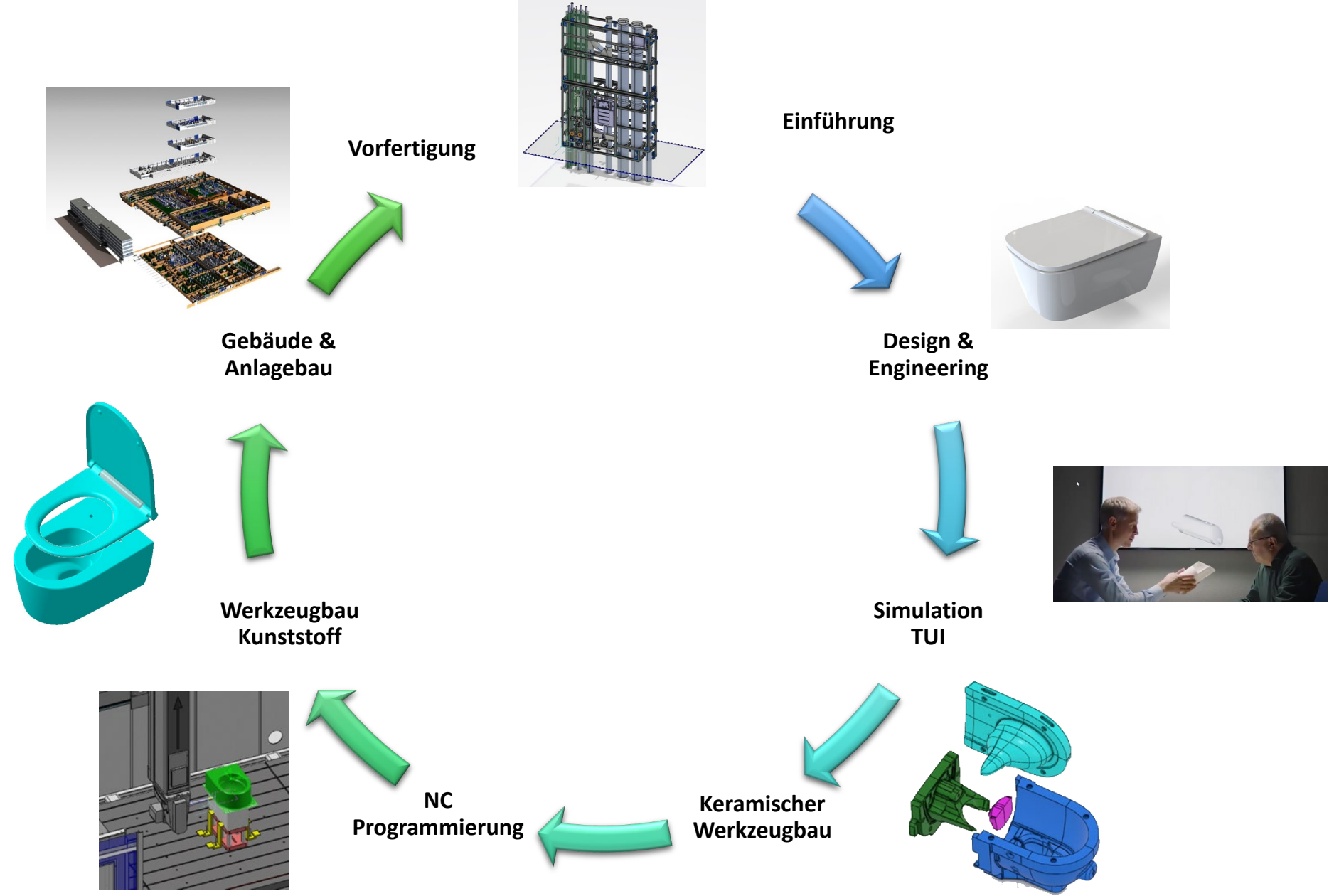

System setup

510 Anwender / 11 Länder / 21 Standorte



Prozess:

11 Cax (IT) Spezialisten
5 Externe

3DExperience (Dassault Systems)

Basis:

3 PLM (IT) Spezialisten
1.3 Externe

Productive / Test / Development / Trainings / Out of the Box system -> 5 system landscape on 35 Servers

Zusätzliche Unterstützung:

- IT Netzwerk Team
- IT Service Center
- IT Software Engineering
- SW Hersteller / Reseller

Herausforderungen

- Geografische Verteilung
- Gesamte Wertschöpfungskette
- Produktvielfalt
- Historie / «Individuelle» Prozesse / Unterschiedliche Lösungsansätze
- Top Management Unterstützung
- Finanzen
- Internes Marketing / Kommunikation

- Organisation «PLM» fehlt
- Roadmap - neue Optionen

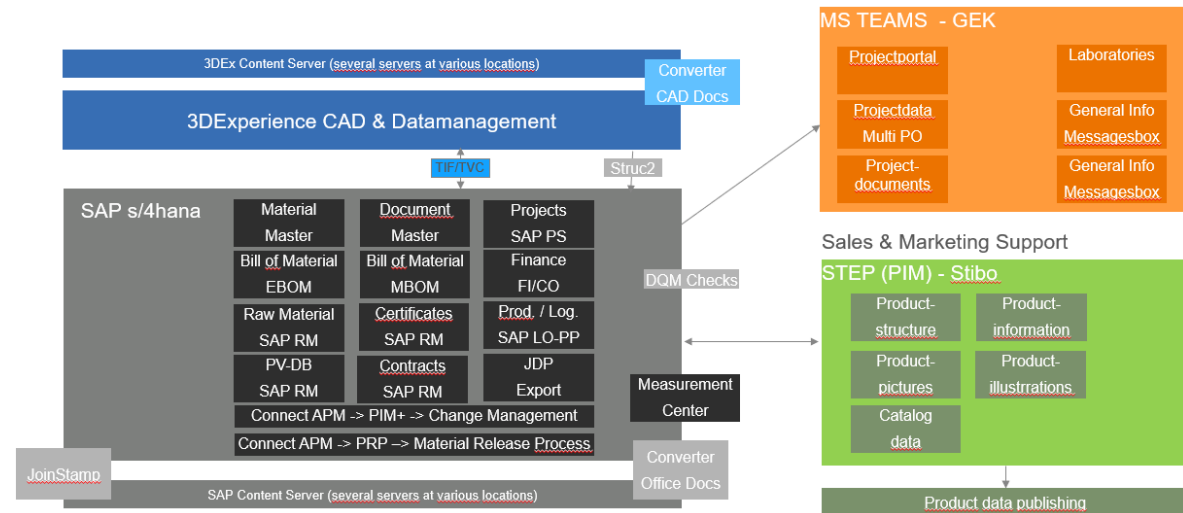



“3DEXPERIENCE on the cloud is a cost-effective way to benefit from superior design technologies without the administrative hassles and costs.”



“I am able to review the system, plan ahead and give them capacity for their priority. It is absolutely amazing as I can also make more precise predictions”



“All product information is stored in the 3DEXPERIENCE platform. Our teams collaborate better and complete projects in less time while improving quality.”

The logo for SCHWINDT, featuring the word "SCHWINDT" in a bold, dark teal sans-serif font. A small red triangle is positioned above the letter "I".The logo for MAPATECH, with "MAPA" in blue and "TECH" in black. A stylized blue and black geometric shape is placed between the two words.

Datengesteuerter Ansatz helfen Projekte auf Kurs zu halten und die Kosten für verspätete Änderungen zu minimieren.

The logo for KREISEL, featuring the word "KREISEL" in a dark grey sans-serif font. To the right is a teal geometric icon resembling a four-pointed star or flower. Below the name is the tagline "WE DRIVE THE FUTURE" in a smaller, lighter grey font.

3DEXPERIENCE Platform for electrifying portfolio of John Deere. Plants in France and USA.

The logo for INNOCEPT engineering. "INNOCEPT" is in a bold, black sans-serif font, with a red curved line underneath it. "engineering" is in a smaller, black sans-serif font below the red line.

Easily see results in real time and provide instant feedback for innovation and improvement. Every stakeholder has full transparency across the entire process



 DASSAULT
SYSTEMES

 DX
ALLIANCE

Websites good to know

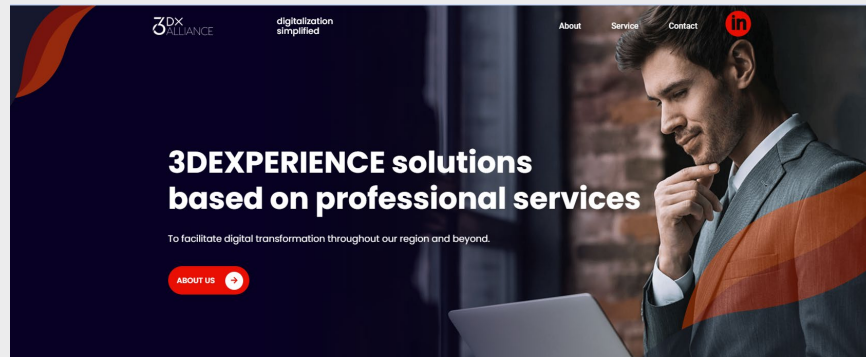

3DX ALLIANCE:
<https://3dx-alliance.eu/>

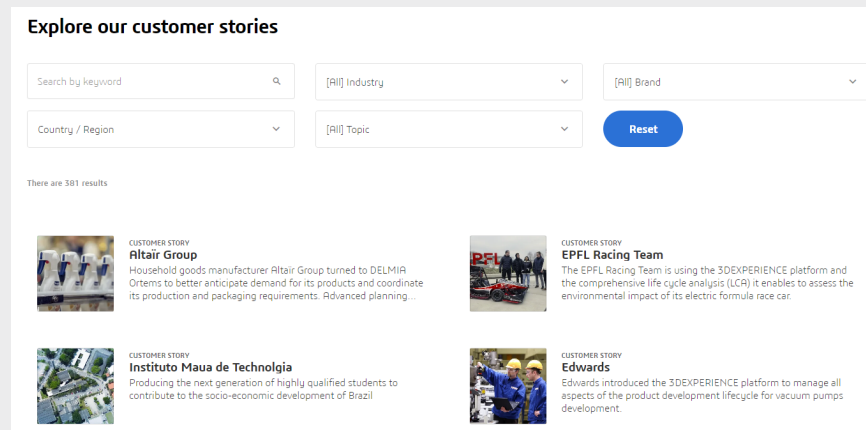

Referenzen:
<https://www.3ds.com/insights/customer-stories>

Upcomming Events

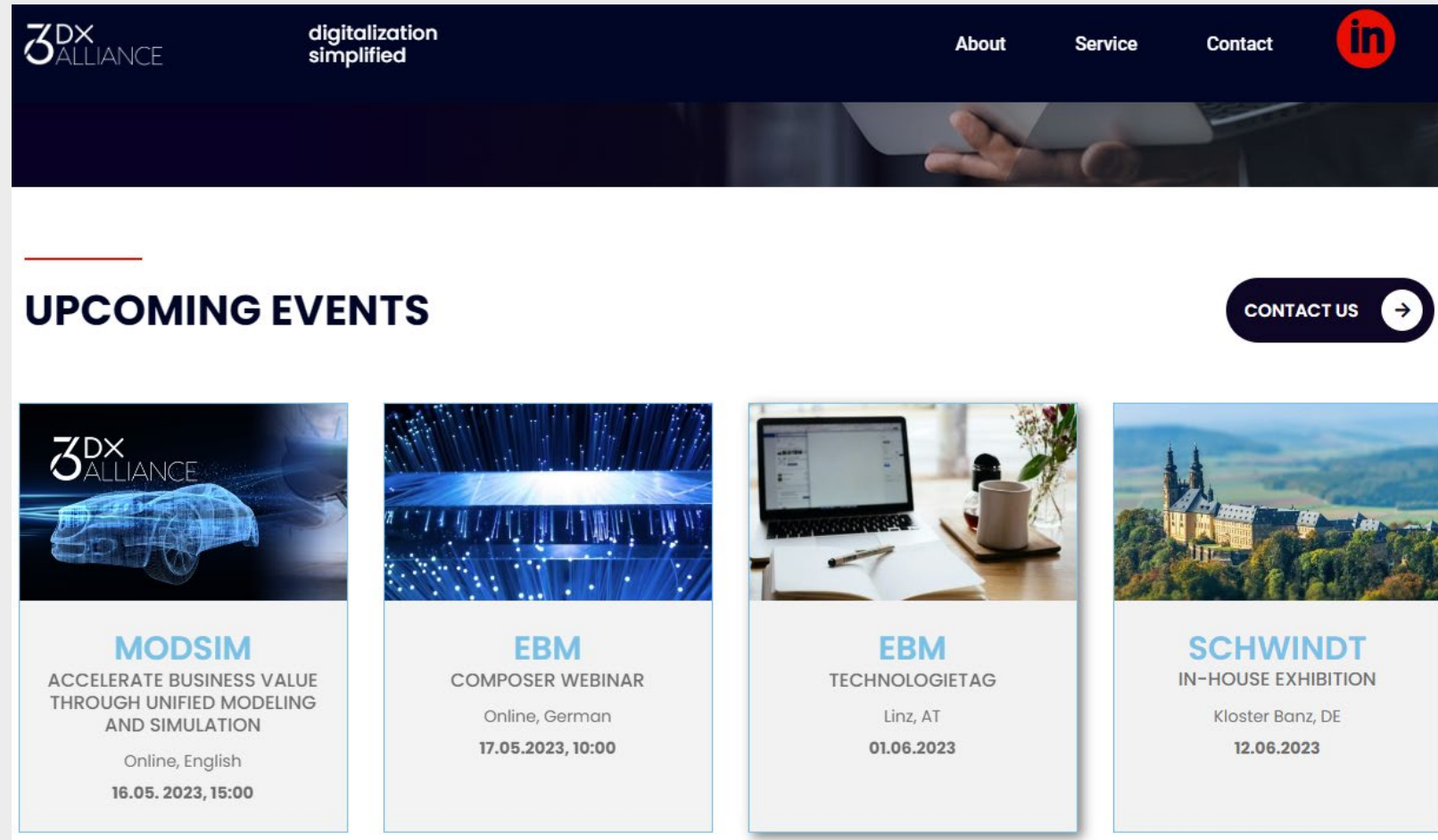

The screenshot shows the top navigation bar of the 3DX Alliance website. The logo '3DX ALLIANCE' is on the left, followed by the tagline 'digitalization simplified'. Navigation links for 'About', 'Service', and 'Contact' are in the center, and a LinkedIn icon is on the right. Below the navigation bar is a dark banner image of a hand holding a tablet. The main content area features a 'UPCOMING EVENTS' section with a 'CONTACT US' button. Four event cards are displayed in a row, each with a header image, event title, description, location, and date.

3DX ALLIANCE digitalization simplified About Service Contact 

UPCOMING EVENTS

[CONTACT US →](#)

MODSIM

ACCELERATE BUSINESS VALUE
THROUGH UNIFIED MODELING
AND SIMULATION

Online, English

16.05. 2023, 15:00



EBM

COMPOSER WEBINAR

Online, German

17.05.2023, 10:00



EBM

TECHNOLOGIETAG

Linz, AT

01.06.2023



SCHWINDT

IN-HOUSE EXHIBITION

Kloster Banz, DE

12.06.2023

29. Juni 2023 Helbling
Kundenevent Schweiz

Fragen?

